

---

WestRock  
**EvoClip™**

## The choice for flexibility and customization

WestRock EvoClip™ is a robust wrap and clip machine for drinkable dairy products in plastic bottles.

- Allows flexible and efficient operation at high speed
- Enables easy operation with servo drive system and automatic subassembly repositioning
- Improves line efficiency with optional integrated tertiary packaging module



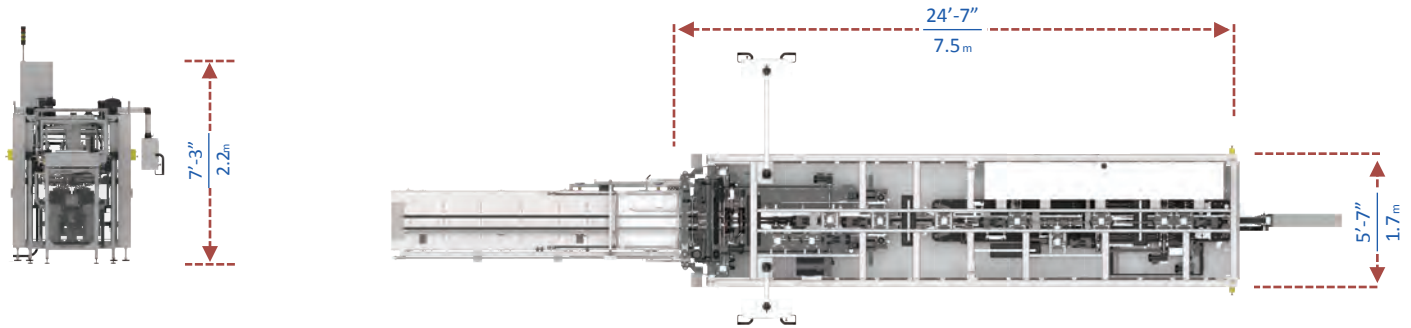

## Features

- Omni-directional touchscreen operator panel
- Full servo drive system
- Auto lubrication system
- Removable locking section

## Primary Container

- Plastic dairy bottles
- Height between 110mm & 210mm
- Diameter between 38mm & 65mm



## Package Formats

- 2x2 through 2x7

## Package Styles

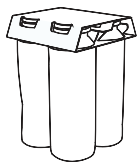

Cluster-Clip



Cluster-Pak®  
over the top

## Maximum Speeds

- 250 packs/minute

## Air & Power Requirements

- Air: 5 Nm<sup>3</sup>/hr at 6 bars
- Power: Customized to specific customer requirements

## Changeover

- Single operator changeover in 5-45 minutes

## Options

- Extended hopper (5000 carton capacity)
- Integrated tertiary packaging module
- Stainless steel construction

Note: All illustrations and specifications are subject to change without notice, and drawing dimensions are approximate and not to scale.