

WestRock

DuoDozen[®] 1250X

Extend your portfolio. Transform your market.

WestRock DuoDozen[®] 1250X offers all the power, performance and functionality of the 1250M platform, while also enabling unique package styles and configurations.

- Delivers comparably high speeds and performance to DuoDozen[®] 1250M, the industry standard for consistent output at high speeds
- Offers tool-less changeovers with servo-enabled repeatability and auto machine prime on start up
- Enables even greater flexibility to not only accommodate different primary heights and diameters, but also new nested shapes and unique product counts

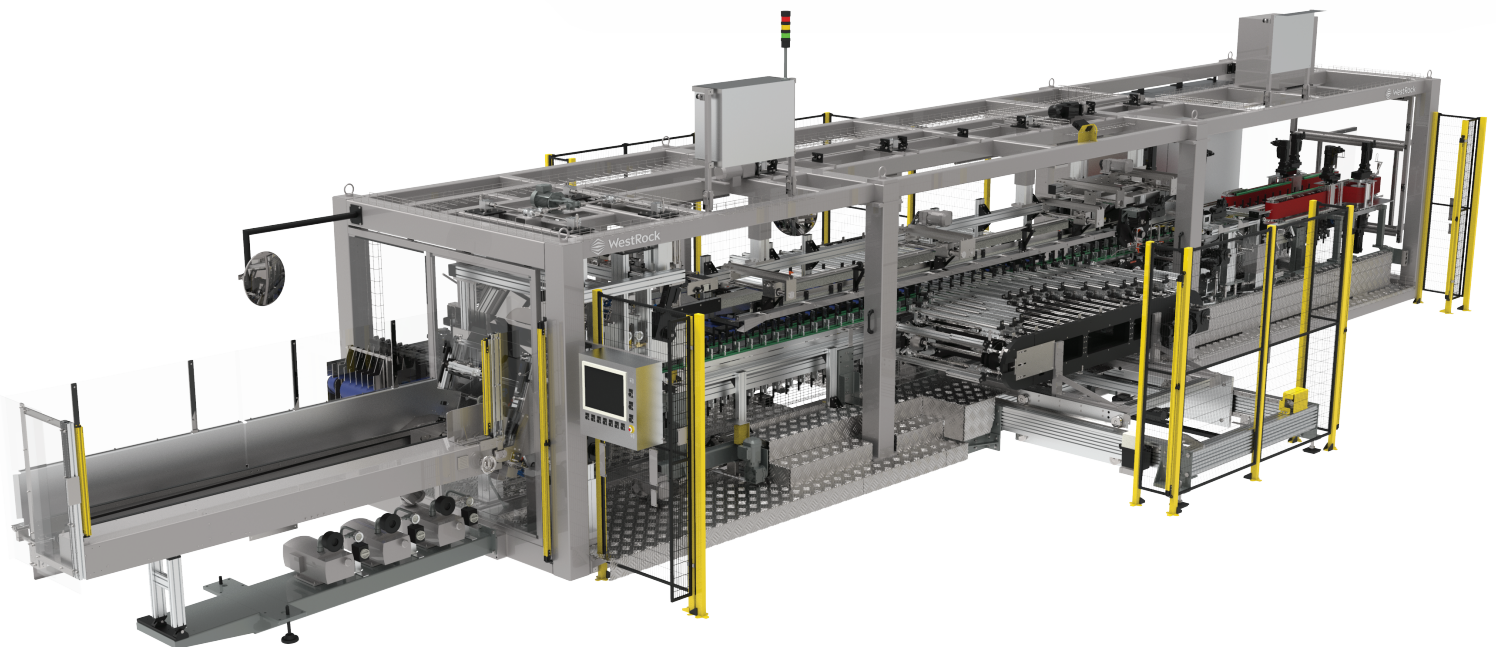

DuoDozen® 1250X

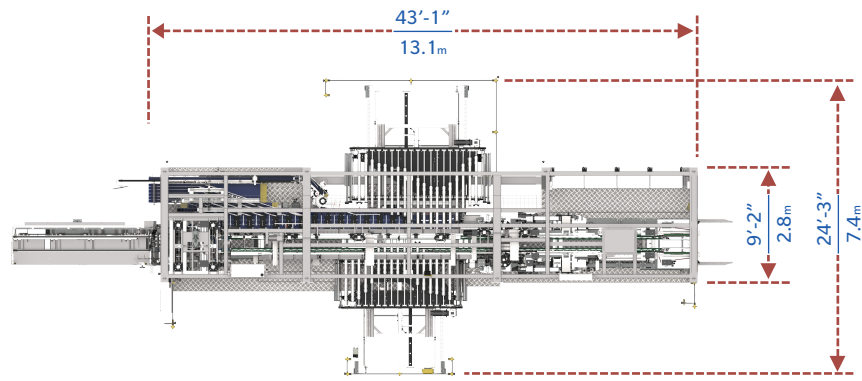
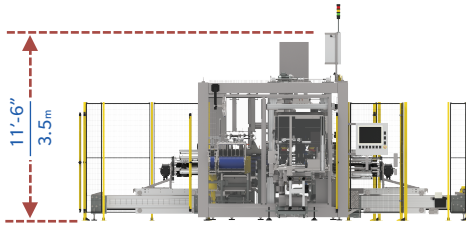

Features

- Auto lubrication system
- Integrated electrical panel
- Auto machine prime
- Light curtain safety system
- Nordson hot melt glue system
- Waist level carton hopper

Primary Container

- Aluminum cans
- Height between 110mm & 159mm
- Diameter between 57mm & 66mm

Package Formats

- Standard packs: 2x2 through 4x6
- XForm™ (shaped) packs: 7 pack through 22 pack

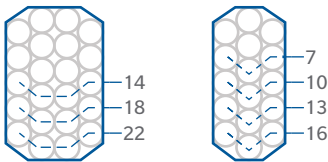

Package Styles

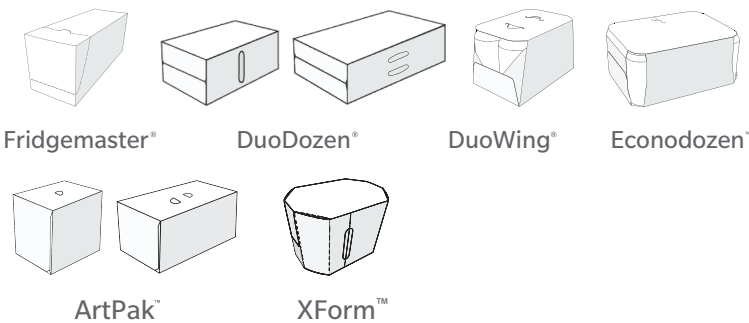

Maximum Speeds

- 2x2 & 2x3: 300 packs/minute
- 2x6: 220 packs/minute
- 3x packs: 140 packs/minute
- 4x packs: 100 packs/minute
- XForm™ packs: 140 packs/minute

Air & Power Requirements

- Air: 8 scfm @ 90 psi
- Power: 480V
- Option for other power requirements as needed

Control System

- Full servo system using Bosch motors, drives & controller
- A-B Control Logix PLC
- Touch screen HMI control panel

Changeover

- Repeatabe and tool-less changeover aided by motorized positioning and HMI checklist

Note: All illustrations and specifications are subject to change without notice, and drawing dimensions are approximate and not to scale.

For more information contact
pkgequipment@westrock.com

Revision: September 2019

©2019 WestRock Company. All rights reserved.

westrock.com/beverage

